



# RF Harmonic Lowpass Filters

## 17841 / 17842 Series

These lowpass filters are designed to suppress undesired HPA harmonic emissions - with minimal impact on the primary signals.

- Choose from a Wide Variety of Cut-Off Frequencies (720 kHz - 120 MHz)
- 2nd thru 5th Harmonic Rejection
- 250 Watt (CW) Power Rating

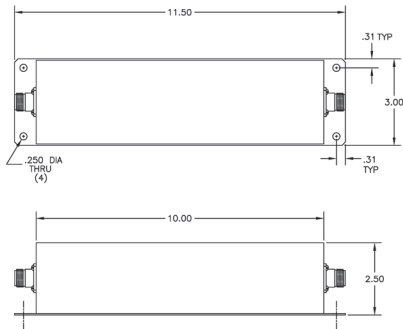

17841 Technical Specifications			
(*) Dash No.	Passband	Insertion Loss	50 dB Min Rejection
-1	0 - .723 MHz	0.7 dB Max 0.5 dB Design Goal	.940 - 3.615 MHz
-2	0 - .984 MHz	0.7 dB Max 0.5 dB Design Goal	1.279 - 4.92 MHz
-3	0 - 1.340 MHz	0.7 dB Max 0.5 dB Design Goal	1.742 - 6.7 MHz
-4	0 - 1.790 MHz	0.7 dB Max 0.5 dB Design Goal	2.327 - 8.95 MHz
-5	0 - 3.07 MHz	0.7 dB Max 0.5 dB Design Goal	3.991 - 15.35 MHz
-6	0 - 4.23 MHz	0.7 dB Max 0.5 dB Design Goal	5.499 - 21.15 MHz
-7	0 - 5.85 MHz	0.7 dB Max 0.5 dB Design Goal	7.605 - 29.25 MHz
-8	0 - 8.08 MHz	0.7 dB Max 0.5 dB Design Goal	10.504 - 40.4 MHz
-9	0 - 11.2 MHz	0.7 dB Max 0.5 dB Design Goal	14.56 - 56 MHz
-10	0 - 15.4 MHz	0.7 dB Max 0.5 dB Design Goal	20.02 - 77 MHz
-11	0 - 21.2 MHz	0.7 dB Max 0.5 dB Design Goal	27.56 - 106 MHz

Common Specifications 17841			
VSWR:	1.36:1 Max	Weight:	4.5 lbs. Approx
Power:	250 Watts	Finish:	Flat Black
Connectors:	N-female	Indoor Use	

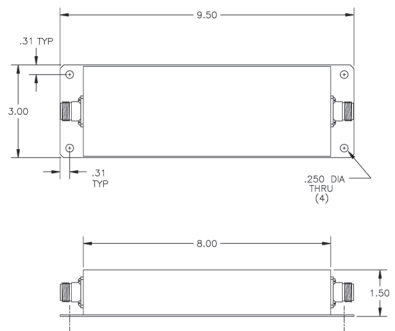

17842 Technical Specifications			
(*) Dash No.	Passband	Insertion Loss	50 dB Min Rejection
-1	0 - 29.4 MHz	0.7 dB Max 0.5 dB Design Goal	38.2 - 147 MHz
-2	0 - 33.4 MHz	0.7 dB Max 0.5 dB Design Goal	43.4 - 167 MHz
-3	0 - 72.3 MHz	0.7 dB Max 0.5 dB Design Goal	93.9 - 361.5 MHz
-4	0 - 87.78 MHz	0.7 dB Max 0.5 dB Design Goal	114.1 - 439 MHz
-5	0 - 97.7 MHz	0.7 dB Max 0.5 dB Design Goal	127 - 488.5 MHz
-6	0 - 120 MHz	0.7 dB Max 0.5 dB Design Goal	156 - 600 MHz

Common Specifications 17842			
VSWR:	1.36:1 Max	Weight:	1.65 lbs. Approx
Power:	250 Watts	Finish:	Flat Black
Connectors:	N-female	Indoor Use	

**MICROWAVE FILTER CO., INC.**  
 6743 KINNE STREET, E. SYRACUSE, NY 13057  
 E-Mail: [mfcsales@microwavefilter.com](mailto:mfcsales@microwavefilter.com)

800-448-1666 • 315-438-4700  
 Web: [www.microwavefilter.com](http://www.microwavefilter.com)